



RENAULT
Passion for life

New Renault KADJAR



1 January 2019



An athletic appearance

An SUV through and through, the new Renault KADJAR proudly sports its adventurous look and powerful design. Evidencing its authentic personality, its chrome-finish grille surrounded by LED lights* really make New Kadjar stand out. At the rear, fog lights keep watch: dust, mist, drizzle, nothing will stop you. Featuring new front and rear skid plates, the 19" alloy wheels^ are ready to take up any kind of terrain. And the shark fin antenna† on the roof combines perfect aerodynamics and unique style.

*Available from S Edition

^Available from Iconic

†Shark fin antenna from Iconic

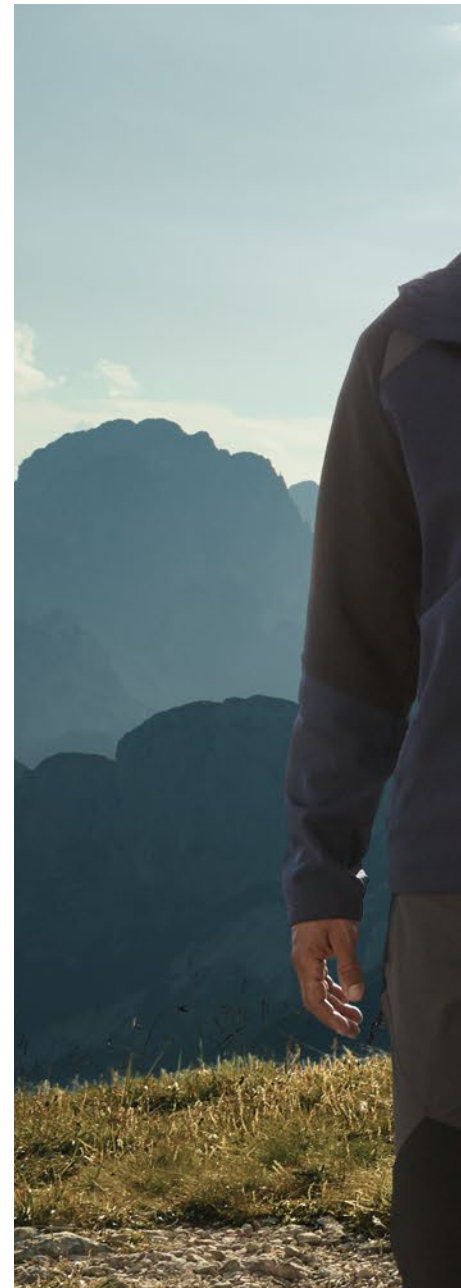







On-board comfort

Explore every detail of your New Kadjar's interior comfort. With its contemporary environment, perfect ergonomic design, new upholstery and chrome-finish trim, you'll enjoy every moment you spend inside it. Comfortably installed at the controls of your New Kadjar, you'll be ready to appreciate the most demanding of roads. The restyled dashboard, the back-lit central console and numerous redesigned details will make you want to embrace adventure in a whole new way.







Ready for all discoveries

New Renault KADJAR excels on the most improbable terrain. A truly seasoned adventurer, it adapts to different driving conditions, with the option to easily switch from two-wheel to four-wheel drive with an intuitive three-position dial: 2WD, Lock or Auto*. With its raised ground clearance, chrome-finish side protection fittings and front and rear skid plates, it will take on challenging terrain just as easily as it does your everyday journeys. New Kadjar will offer you comfort regardless of the road ahead.

Intuitive 2W/4W dial

Simply turn it to adapt the traction system to your driving conditions. Three options available:

- **2WD:** two-front-wheel drive
- **Lock:** four-wheel-drive continuously
- **Auto:** automatic selection of two-wheel or four-wheel drive, depending on driving conditions

* Available soon on GT Line dCi 150 engines only.

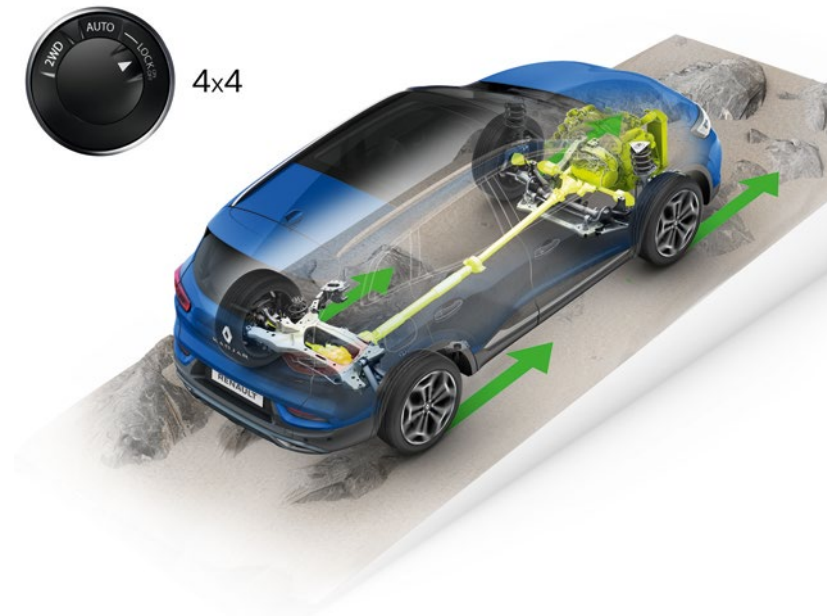



Adaptive instinct

You'll also find plenty of spaces inside your new Renault KADJAR. By simply folding down the rear bench seat*, in the flat position you'll enjoy substantial loading volume that is easy-to-use when the floor of the boot is in the raised position. Mountain bikes, rucksacks, hiking equipment and accessories letting you take on life. And your passengers will be spoiled: the large cup holders in the front, together with the air-conditioning vents and USB ports in the rear* will change the whole travel experience for them. And as the driver, you'll be nicely cradled in your heated adjustable seat with sliding armrests, ready to enjoy the most demanding of roads. Yes to adventure – but with everything you need to enjoy it to the full!

*Available from Iconic





Efficiency without compromise

The engines powering the Renault KADJAR are advanced, reliable and improved fuel consumption. Fitted with the Stop & Start system with regenerative braking, they include a host of technologies (downsizing, friction reduction, latest-generation injection systems) that elevate them to exemplary levels of performance and consumption, all without sacrificing your driving pleasure.

TCe 140 **Flexibility and control**

Flexible and responsive from low rpm, this petrol engine deliver power with its turbo function and economy with low fuel consumption.

Blue dCi 115

The Renault Kadjar benefits from the latest Blue dCi diesel engines which are equipped with a system to reduce polluting Nitrogen Oxide vehicle emissions by injecting an urea-based fluid, AdBlue®, into the exhaust system. A dashboard message will remind you when the AdBlue® needs topping up via specific Adblue filling cap located next to the usual Diesel fuel filler cap. A full tank of Adblue will last for 6 full tanks of Diesel. The Blue dCi 115 engine features overboost providing additional power and torque when accelerating.

TCe 160

This latest generation petrol engine from Renault feautres technologies to help increase torque and reduce CO₂. As a result the TCe 160 delivers driver pleasure around town or on motorway routes.

EDC gearbox **Comfort, moderate** **consumption and technology**

This 6-speed automatic dual-clutch gearbox offers smooth, jerk-free gear changes Dynamic and responsive, the EDC responds almost instantly to the slightest driver input. In terms of economy, its fuel consumption is similar to that of a mechanical gearbox. Available with the Blue dCi 115 engine, the EDC gearbox is ideal for an enjoyable and relaxed drive in all conditions.





The world at your fingertips

Integrated into the new central console, the R-LINK2[^] multimedia system's 7" touchscreen is highly ergonomically-designed and intuitive. When connected, R-LINK 2 gives you access to a wide range of services such as TomTom[™] Traffic* so you get the latest traffic information in real time. With Android Auto^{™**} and Apple CarPlay^{™**}, easily access your smartphone's driving-compatible apps directly from the R-LINK 2 screen. With the MY Renault^{**} application connected to your R-LINK 2, take advantage of smart services wherever you are and at any time (to find where you've parked your Renault Kadjar, for example!). R-LINK 2 optimises the on-board experience and delivers a fluid, simple and customised multimedia experience.

*For a limited period.

[^]Available from Iconic

** Compatibility: An Android phone running Android 5.0 (Lollipop), an iPhone no earlier than iPhone 5 & iOS7.1. Connecting a smartphone to access Android Auto[™] and Apple CarPlay[™] should only be done when the vehicle is safely parked. Drivers should only use the system when it is safe to do so and in compliance with the requirements of The Highway Code. Drivers should be aware of the potential of hands-free technology to distract a driver's attention from the road, preventing them from having full control of the vehicle.

Controlled trajectories

To make sure that you have as much control as possible during each and every one of your adventures, 2 cameras, 12 sensors and a radar keep a constant watch on your movements. The speed alert system with traffic sign recognition* system helps you adapt your driving to road sign data captured by the camera. A visual alert is shown on your dashboard and suggests saving it as the value for the speed limiter.

The lane departure warning^ will let you know when you have strayed across a continuous broken line without indicating.

*Available on GT Line only

^Available from Iconic







New Renault KADJAR
Feel comfortable on any adventure

Standard features

PLAY



ATHENA - 17" alloy wheels



Dark Carbon fabric upholstery



Driving Assistance

- ABS with EBD – Electronic brake distribution and emergency brake assist
- Driver and passenger adaptive front airbags (passenger airbag can be disabled)
- Airbags - curtain front and rear
- Airbags - driver's two stage adaptive airbag
- Airbags - Front lateral
- Automatic headlights
- Cruise control with speed limiter
- Deadlocking and immobiliser
- Eco-Mode
- Electrical Parking Brake
- Front fog lamps with cornering function
- Gear Change Indicator
- Hill start assist
- Height adjustable drivers seat belt with 3 points rear centre seatbelt
- Insurance approved (Category 1) alarm system and immobilizer

- ISOFIX Child seat anchorage points on rear outer seats
- Integrated C Shape Indicators with side repeaters
- Rear parking sensors
- R.A.I.D (Renault Anti Intruder Device) auto closure >6mph
- Seats - height adjustable front seatbelts with double pretensioners
- Side impact protection bars
- Tyre pressure monitor system
- 3 points rear center seatbelt
- Tyre Inflation Kit
- Tyre Pressure Monitor

Exterior

- 17" alloy wheels – ATHENA
- Body side moulding
- Door handles body coloured
- Door mirrors - body coloured shell
- Windows chrome surround
- LED DRL - Daytime running lights

Interior

- Back-illuminated central console
- Daylight/nightlight rear-view mirror
- Display - digital speedometer (TFT Screen)
- Heated rear screen
- Sliding front centre armrest
- Windows - tinted rear and tailgate
- 60:40 split folding seats
- Cloth Upholstery – Dark Carbon Fabric

Comfort and Convenience

- Accessory Power point
- Adjustable dashboard illumination
- Automatic dual zone climate control
- Driver – height adjustable seat
- Electric Front windows
- Electric Rear Windows
- Exterior temperature indicator
- Floor mats – front and rear
- Halogen headlights
- Heated rear windscreen

- Socket front – 12v socket

- Multi-functional trip computer
- Steering wheel – power assisted, height, rake and reach adjustable
- Storage – glove box
- Trip computer and rev counter
- Windscreen wipers – Automatic with variable speed adjustment
- 3 button retractable key

Connectivity and Sound System*

- 7" Screen with smartphone integration
- Bluetooth connectivity*
- FM/ AM/DAB tuner, 4 x20W speakers Bluetooth** audio streaming and hands-free calls, USB and AUX sockets

*For compatible devices, please refer to <https://www.renault.co.uk/services/multimedia/bluetooth-compatibility.html>

Standard features

ICONIC (additional equipment to Play)



ZEUS - 19" diamond cut alloy wheels



Black Fabric upholstery



Driving Assistance

- Automatic High and Low Beam
- Front and rear parking sensors with a rear parking camera
- Lane Departure Warning

Exterior

- 19" Diamond Cut 'Zeus' alloy wheels
- Body side mouldings with chrome inserts
- Electric folding automatic and heated door mirrors
- Extra tinted windows
- Roof rails – Chrome look
- Shark fin Antenna

Interior

- Synthetic Leather and Cloth upholstery
- Passenger height adjustable seat
- Synthetic leather steering wheel

Comfort and Convenience

- Automatic high/low beam
- Driver sunblind with illuminated mirror and ticket holder
- Driver – height and lumbar adjustable seat
- Door Mirrors - Electrically adjustable, heated and folding
- EasyLife quick folding rear seats
- Keycard - hands-free with walk away lock function
- Rear passenger air vents
- Lane departure warning
- Multi positional boot floor

Connectivity and Sound System*

- R-Link 2 multimedia system: 7" touchscreen, TomTom™ LIVE services with Western European Mapping, FM/AM/DAB tuner, Bluetooth®* audio streaming and hands-free calls, USB and AUX sockets, voice control, vehicle applications
- Two rear USB sockets
- 4x35W speakers with 3D sound

Standard features

S EDITION (additional equipment to Iconic)



ZEUS - 19" diamond cut alloy wheels



Black fabric upholstery with blue top-stitching



Driving Assistance

- LED high & low beam headlights with LED turn indicators
- LED Fog lamps with cornering function

Exterior

- 19" Diamond Cut 'Zeus' alloy wheels
- Chrome finish fog light surrounds
- Fixed glass panoramic sunroof
- Saturn Grey front and rear skid plates
- Side and boot kick plates

Interior

- Dark Blue 3D TEP fabric with synthetic leather upholstery with Blue top-stitching
- Auto-dimming rear-view mirror

Connectivity and Sound System*

- R-Link 2 multimedia system: 7" touchscreen, TomTom™ LIVE services with Western European Mapping, FM/AM/DAB tuner, Bluetooth®* audio streaming and hands-free calls, USB and AUX sockets, voice control, vehicle applications
- Two rear USB sockets
- 4x35W speakers with 3D sound

Standard features

GT LINE (additional equipment to S Edition)



POSEIDON - 19"



Dark leather upholstery



Driving Assistance

- AEBS – Active Emergency Braking
- Blind spot warning with lateral sensors
- Over speed and traffic sign recognition
- Flank Protection

Exterior

- 19" Diamond cut 'POSEIDON' alloy wheels
- Front Grille with chrome enrichment
- Adamantium front & rear skid plates

Interior

- Carbon Black Leather Upholstery with synthetic leather head rest
- Leather steering wheel

Comfort and Convenience

- Hands Free Parking
- Heated front seats and electrically adjustable driver's seat (fore/aft, height and recline)
- Driver and passenger cushion length extender

Connectivity and Sound System

- BOSE™ energy efficient sound system: 7 speakers with a digital amplifier + 1 Subwoofer

Colours

Iron Blue (3) (RQH)



Oural green (3) (DPY)



Flame Red (3) (NNP)



Cosmos Blue (2) (RPR)



Pearl White (3) (QNC)



Highland Grey (2) (KQA)



Titanium Grey (2) (KPN)

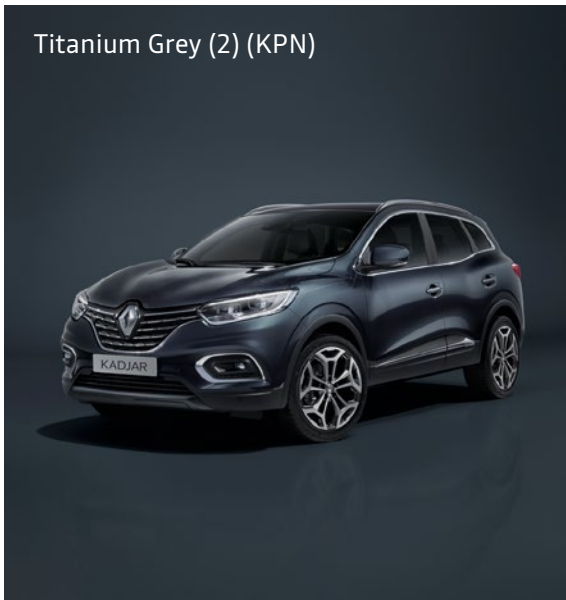

Diamond Black (2) (GNE)

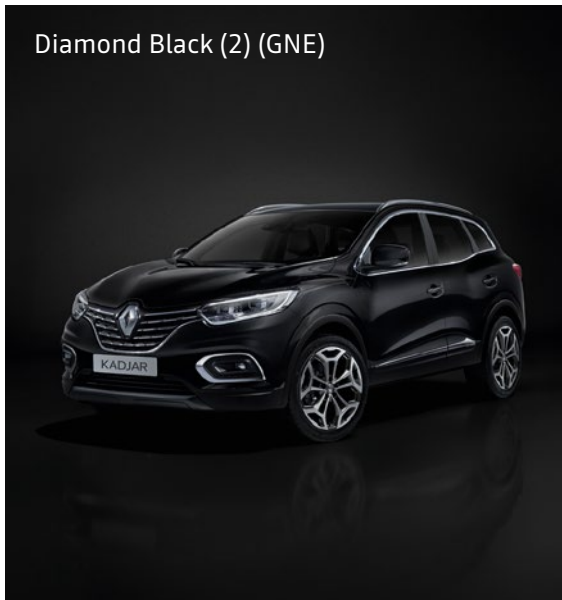

Glacier White (1) (369)

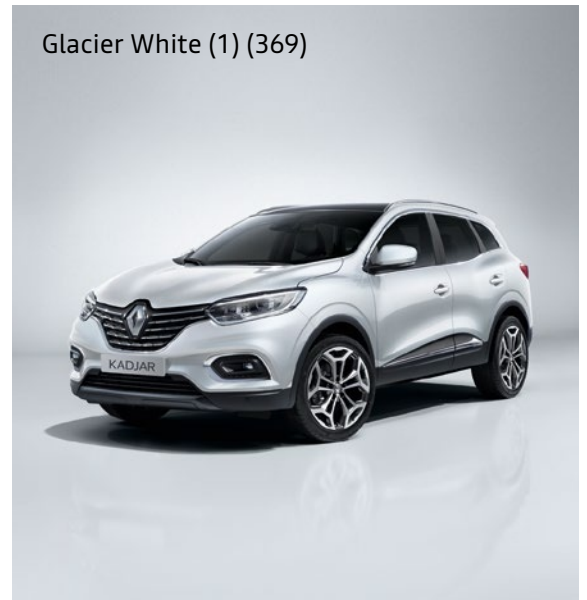

Every effort has been made to ensure that the information, descriptions, and images were correct at the time of publication however images may not always reflect the exact version selected. It should be noted that limitations on screen do not permit the subtle paintwork shades on this page to be shown with absolute accuracy.

Equipment and options

	Play	Iconic	S Edition	GT Line
DRIVING ASSISTANCE				
Driver and passenger adaptive front airbags (passenger airbag can be disabled)	•	•	•	•
ABS with Emergency Emergency Brake Assist	•	•	•	•
AEBS - Active Emergency Braking System	-	-	-	•
Airbags - curtain front and rear	•	•	•	•
Airbags - driver's two stage adaptive airbag	•	•	•	•
Airbags - deactivation of front passenger (for use with child seats)	•	•	•	•
Airbags - Front lateral	•	•	•	•
Airbag - front passenger's two stage adaptive airbag	•	•	•	•
Intergrated C Shape Indictaors with side repeaters	•	•	•	•
Automatic headlights and wipers	•	•	•	•
Automatic High and Low Beam	-	•	•	•
Cruise control with speed limiter	•	•	•	•
ESP (Electronic Stability Programme) with ASR (Anti-Skid Regulation) and UCL (Understeer Logic Control)	•	•	•	•
Lane Departure Warning	-	•	•	•
Speed alert with traffic sign recognition	-	-	-	•
Blindspot Warning	-	-	-	•
LED Front fog lights with corner function	-	-	•	•
Front fog lights with corner function	•	•	-	-
Rear LED fog lights	•	•	•	•
Halogen headlights	•	•	-	-
Full LED headlights	-	-	•	•
Power Assisted Steering	•	•	•	•
Rear Parking Sensors	•	-	-	-
Front and rear parking sensors	-	•	•	•
Rear parking camera (incl. Front and rear sensors)	?	•	•	•
Height adjustable drivers seat belt	•	•	•	•
3 points rear center seatbelt	•	•	•	•
Protective rear brake disc	•	•	•	•
Seats - height adjustable front seatbelts with double pretensioners	•	•	•	•
ISOFIX Child seat anchorage points on rear outer seats	•	•	•	•
Side impact protection bars	•	•	•	•
Tyre Inflation Kit	•	•	•	•
Tyre Pressure Monitor	•	•	•	•
Flank protection	-	-	-	•
R.A.I.D (Renault Anti Intruder Device) auto closure >6mph	•	•	•	•
Deadlocking and immobilisher	•	•	•	•
Insurance approved (Category 1) alarm system and immobilisher	•	•	•	•
Eco-Mode	•	•	•	•
LED DRL - Daytime running lights	•	•	•	•
Hill start assist	•	•	•	•
Gear Change Indicator	•	•	•	•
Electrical Parking Brake	•	•	•	•
EXTERIOR FEATURES				
17" alloy wheels - ATHENA	•	-	-	-
19" alloy wheels - ZEUS	-	•	•	-
19" alloy wheels - POSEIDON	-	-	-	•
Puddle Lamp	-	-	-	•
Roof rails	-	•	•	•
Fixed panoramic sunroof	-	-	•	•
Electric door mirrors manual folding - heated	•	-	-	-
Door Mirrors - Electrically adjustable, heated and folding	-	•	•	•
Door handles body coloured	•	•	•	•
Door mirrors - body coloured shell	•	•	•	•
Body side moulding	•	-	-	-
Body sided mouldings with chrome inserts	-	•	•	•
Satin grey front and rear skid plates	-	-	-	-
Adamantium grey front and rear skid plates	-	-	-	•
Front fog lights chrome surround	-	-	•	•
Chrome inserts on front grille	-	-	-	•
Windows chrome surround	•	•	•	•
Side and boot kick plates	-	-	-	•
INTERIOR DESIGN				
WINDOWS				
Heated rear screen	•	•	•	•
Electric Front windows	•	•	•	•
Electric Rear Windows	•	•	•	•
Windows - tinted rear and tailgate	•	-	-	-
Windows- Extra Tinted rear and tailgate	-	•	•	•

	Play	Iconic	S Edition	GT Line
SEATING				
Cloth Upholstery - Dark Carbon fabric	●	-	-	-
Synthetic Leather and Cloth upholstery	-	●	-	-
Dark Blue 3D TEP fabric with synthetic leather upholstery with Blue top-stitching	-	-	-	-
Carbon Black Leather Upholstery with synthetic leather head rest	-	-	-	●
Driver - height adjustable seat	●	●	●	●
Driver - height adjustable seat with lumbar support	-	●	●	●
Passenger height adjustable	-	●	●	●
Driver and passenger cushion length extender	-	-	-	●
Fully adjustable front headrests	●	●	●	●
Height adjustable front seat belts	●	●	●	●
Heated front seats and electrically adjustable driver's seat (fore/aft, height and recline)	-	-	-	●
3-point inertia reel seatbelts	●	●	●	●
3-seat rear bench	●	●	●	●
60:40 split folding seats	●	●	●	●
3 height adjustable rear head restraints	●	●	●	●
STORAGE				
Sliding front centre armrest	●	●	●	●
Central rear armrest with cup holders	-	●	●	●
Multi position boot floor	-	●	●	●
EasyLife quick folding rear seats	-	●	●	●
DASHBOARD				
Multi functional trip computer	●	●	●	●
Rev-counter	●	●	●	●
Display - digital speedometer (TFT Screen)	●	●	●	●
Adjustable dashboard illumination	●	●	●	●
Low fuel level warning light	●	●	●	●
Oil level gauge	●	●	●	●
Exterior Temperature gauge	●	●	●	●
Rear seat belt undone audible alert	-	●	●	●
Driver and passenger seat belt undone - warning audible alert	●	●	●	●
Door/boot open - warning light	●	●	●	●
Daylight/nightlight rearview mirror	●	●	-	-
Auto-dimming Rear View Mirror	-	-	●	●
OPENINGS				
Keycard - handsfree with walk away lock function	-	●	●	●
3 button retractable key	●	-	-	-
HEATING AND VENTILATION				
Air recirculation facility	●	●	●	●
Pollen filter	●	●	●	●
Automatic dual zone climate control	●	●	●	●
Heated rear windscreen	●	●	●	●
Rear passenger airvents	-	●	●	●
INTERIOR LIGHTING				
Interior Courtesy light controlled by all 4 doors	●	●	●	●
Driver and passenger reading lights	●	●	●	●
Rear courtesy lights	●	●	●	●
Illuminated luggage compartment (on opening of boot)	●	●	●	●
Back-illuminated central console	●	●	●	●
COMFORT				
Accessory Power point	●	●	●	●
Two rear USB sockets	-	●	●	●
Faux leather steering wheel	●	●	●	-
Leather steering wheel	-	-	-	●
Floor Mats Front and Rear	●	●	●	●
Hands Free Parking	-	-	-	●
Steering wheel - rake and reach adjustable	●	●	●	●
Sun visor with mirror without light	●	-	-	-
Sun visor with mirror with light	-	●	●	●
IN CAR ENTERTAINMENT^A				
Fingertip audio system remote control	●	●	●	●
FM/ AM/DAB tuner, 4 x20W speakers Bluetooth® audio streaming and hands-free calls, USB and AUX sockets	●	-	-	-
Smartphone intergration compatible with AppleCar play™ and Android Auto™	●	●	●	●
4 x 35W speakers with 3D sound	-	●	●	-
BOSE™ energy efficient sound system: 7 speakers with a digital amplifier + 1 Subwoofer	-	-	-	●
R-Link 2 multimedia system: 7" touchscreen, TomTom® LIVE services with Western European Mapping, FM/AM/DAB tuner, Bluetooth® audio streaming and hands-free calls, USB and AUX sockets, voice control, vehicle applications	-	●	●	●

● = Standard; ○ = Optional; - = Not available. ^ACompatibility: An Android phone running Android 5.0 (Lollipop), an iPhone no earlier than iPhone 5 & iOS7.1. Connecting a smartphone to access Android Auto™ and Apple CarPlay™ should only be done when the vehicle is safely parked. Drivers should only use the system when it is safe to do so and in compliance with the requirements of The Highway Code. Drivers should be aware of the potential of hands-free technology to distract a driver's attention from the road, preventing them from having full control of the vehicle

Key information

For prices, please refer to the Renault Car Price Guide available at your local dealer and on www.renault.co.uk

VERSIONS	CO ₂ (g/km)*	VED year 1	Combined fuel consumption (mpg)*	HP	Benefit in kind†	Insurance group
Play TCe 140 MY19	134	£205	42.1 - 44.1	140	27%	TBC
Play TCe 140 Auto EDC MY19	131	£205	41.5 - 43.5	140	27%	TBC
Play Blue dCi 115 MY19	113	£205	55.3 - 60.1	115	27%	TBC
Play Blue dCi 115 Auto EDC MY19	111	£205	54.3 - 57.6	115	27%	TBC
Iconic TCe 140 MY19	134	£205	42.1 - 44.1	140	27%	TBC
Iconic TCe 140 Auto EDC MY19	131	£205	41.5 - 43.5	140	27%	TBC
Iconic TCe 160 MY19	134	£205	42.1 - 44.1	160	27%	TBC
Iconic Blue dCi 115 MY19	113	£205	55.3 - 60.1	115	27%	TBC
Iconic Blue dCi 115 Auto EDC MY19	111	£205	54.3 - 57.6	115	27%	TBC
S Edition TCe 140 MY19	134	£205	42.1 - 44.1	140	27%	TBC
S Edition TCe 140 Auto EDC MY19	131	£205	41.5 - 43.5	140	27%	TBC
S Edition TCe 160 MY19	134	£205	42.1 - 44.1	160	27%	TBC
S Edition Blue dCi 115 MY19	113	£205	55.3 - 60.1	115	27%	TBC
S Edition Blue dCi 115 Auto EDC MY19	111	£205	54.3 - 57.6	115	27%	TBC
GT Line TCe 140 MY19	134	£205	42.1 - 44.1	140	27%	TBC
GT Line TCe 160 MY19	134	£205	42.1 - 44.1	160	27%	TBC
GT Line TCe 140 Auto EDC MY19	131	£205	41.5 - 43.5	140	27%	TBC
GT Line Blue dCi 115 MY19	113	£205	55.3 - 60.1	115	27%	TBC
GT Line Blue dCi 115 Auto EDC MY19	111	£205	54.3 - 57.6	115	27%	TBC
GT line Blue dCi 150 4 X 2 MY19	TBC	£205	TBC	150	TBC	TBC
GT Line Blue dCi 150 4 X4 MY19	TBC	£205	TBC	150	TBC	TBC

*WLTP figures shown are for comparability purposes; only compare figures with vehicles tested to the same technical procedures. Actual real world driving results may vary depending on factors such as weather conditions, driving styles, vehicle load or any accessories fitted after registration. WLTP is a new test used for fuel consumption and CO₂ figures however until April 2020 the CO₂ figures are based on the outgoing (NEDC) test cycle which will be used to calculate vehicle tax on first registration. Please visit renault.co.uk/configure for WLTP figures for any selected options. †Renault UK Limited does not offer tax advice and recommends that all Company Car Drivers consult their own accountant with regards to their particular tax position.

OPTIONS	Play	Iconic	S Edition	GT Line
Metallic paint (i.d paint includes arctic white, iron blue and flame red)	○	○	○	○
Light Grey Leather Upholstery with synthetic leather rear headrest	-	-	-	○
Emergency Space Saver Spare Wheel	○	○	○	○

● = Standard (therefore no cost); ○ = Optional; - = Not available

EASYLIFE PACK†

EasyLife Servicing Pack

3 Years / 30,000 miles

4 years / 40,000 miles

EasyLife Pack+

Servicing & Extended Warranty 4 years / 60,000 miles

†The EasyLife Pack is available on eligible retail vehicles excluding ZOE and LCV's (Traffic Passenger and Master Combi are also excluded). The pack will expire upon the vehicle reaching XX years from registration or it has reach XX miles whichever comes first and as specified in the pack. Services must be carried out in line with the manufacturer's minimum maintenance programme requirements and servicing intervals within +/- 1 month or 1,000 miles at a Renault Approved outlet. Servicing does not include wear and tear parts including but not limited to brakes, tyres and wiper blades. To qualify you must order and purchase the EasyLife Pack from a Renault Approved outlet or Renault.co.uk before the first service or within 1 month from vehicle registration (whichever comes first). The EasyLife Pack is available on vehicles ordered between 21 December 2018 and 1 April 2019 and only available to be purchased by the first owner of the vehicle (excludes pre-registered & used vehicles). All prices quoted are MRRP. Easy Life Servicing Pack cannot be part exchanged, refunded or transferred. New Kadjars ordered between 21 December 2018 and 1 April 2019 and registered by 30 June will receive a free EasyLife Servicing Pack - 3 years / 30,000 miles.

Dimension diagrams

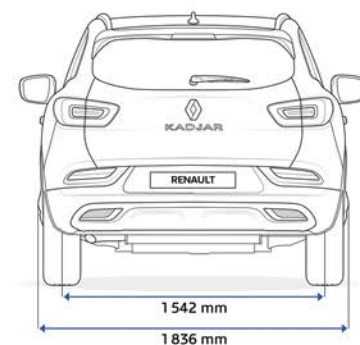
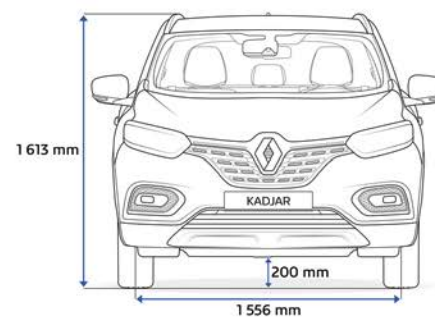
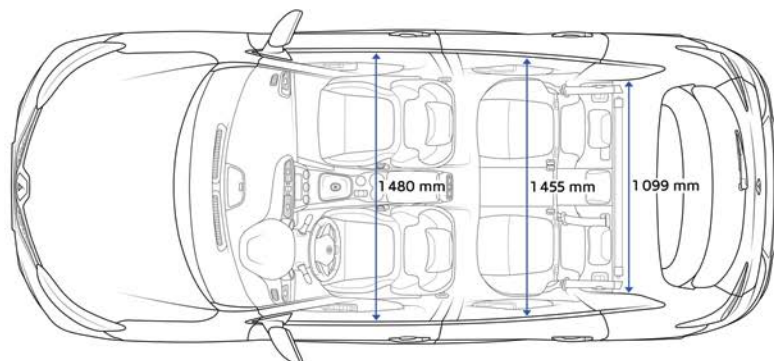
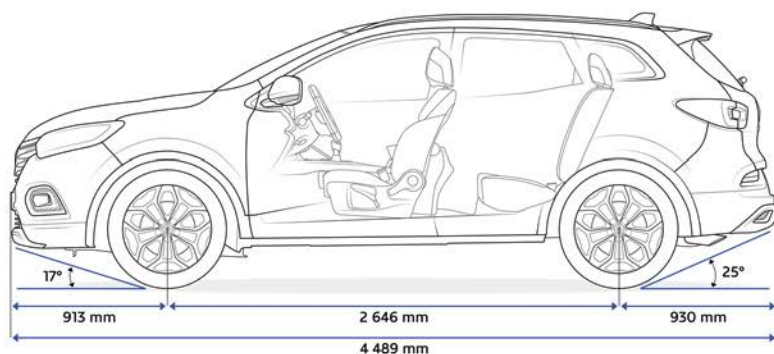

BOOT VOLUME

With inflation kit (VDA volume, dm ³)	472
With inflation kit (volume in litres)	527
Max. loading volume seats folded down (VDA volume, dm ³)	1,478

DIMENSIONED DRAWING (mm)

A	Wheelbase	2,646
B	Overall length	4,449
C	Front overhang	897
D	Rear overhang	906
E	Front track	1,556
F	Rear track	1,542
G	Unladen height with/without door mirrors	1,836 / 2,058
H	Unladen height with longitudinal roof bars	1,607 / 1,613
H1	Height with tailgate open (unladen)	2,069
J	Unladen boot sill height	761

K	Ground clearance	200
L	Knee room in 2 nd row	220
M	Front elbow width	1,480
M1	Rear elbow width	1,455
P	Headroom at 14° in 1 st row (front seats)	905
P1	Headroom at 14° in 2 nd row (rear seats)	910
Y	Interior width between wheel arches	1,099
Z	Max. loading length bench seat folded up/down	864 / 1,620
R/R1	Angles of front/rear bumpers in degrees	18 / 28

Technical Specification

	TCe 140	TCe 160	TCe 140 Auto EDC	Blue dCi 115	Blue dCi 115 Auto EDC
ENGINE					
Engine type	HR13	HR13	HR13	K9K	K9K
Emissions conformance	Euro 6 Dtemp	Euro 6 Dtemp	Euro 6 Dtemp	Euro 6 Dtemp	Euro 6 Dtemp
With Particulate Filter (FAP)	GPF (Gasoline particulate filter)	GPF (Gasoline particulate filter)	GPF (Gasoline particulate filter)	DOC + SCRf	DOC + SCRf
Induction Capacity (cc)	1332	1332	1332	1461	1461
Bore x Stroke	72.2 x 81.4	72.2 x 81.4	72.2 x 81.4	76 x 80.5	76 x 80.5
Maximum power - kw ISO	103 kW	117 kW	103 kW	85 kW	85 kW
Maximum Power - hp DIN	140	160	140	115	115
Maximum power - rpm	5000	5500	5000	3750	3750
Maximum Torque - Nm ISO	240	260	240	260	260
Maximum Torque (rpm)	1600	1750	1600	2000	2000
Fuel Type	Petrol	Petrol	Petrol	Diesel	Diesel
Injection type	Direct Injection	Direct Injection	Direct Injection	Common Rail	Common Rail
No. of Cylinders	4	4	4	4	4
No. of Valves	16	16	16	8	8
PERFORMANCE					
0- 62 mph - secs (0-100 km/h)	10.4	9.9	9.6	11.7	11.5
Maximum Speed mph (km/h)	126 (203)	130 (210)	126 (203)	117 (189)	117 (189)
Standing 1000m in seconds	30.9	29.6	30.8	33.5	33.4
FUEL CONSUMPTION* AND EMISSIONS (IN L/100KM AND G/KM)					
CO ₂ (g/km) (High - Low)	134 - 136	134 - 136	131 - 135	113 - 117	111 - 115
Combined - mpg (High - Low)	42.16 - 44.13	42.16 - 44.13	41.54 - 43.45	55.38 - 60.1	54.32 - 55.38
Combined - l/100 km (High - Low)	6.7 - 6.4	6.7 - 6.4	6.8 - 6.5	5.1 - 4.7	5.2 - 4.9
GEARBOX					
Number of forward gears	6	6	7	6	6
Manual / Automatic	M	M	A	M	A
BRAKING SYSTEM					
Type of braking system	Discs	Discs	Discs	Discs	Discs
ABS	Standard	Standard	Standard	Standard	Standard
EBD	Standard	Standard	Standard	Standard	Standard
Front Ø (mm) / width (mm)	296 / 26	296 / 26	296 / 26	296 / 26	296 / 26
Rear Ø (mm) / width (mm)	290 / 13	290 / 13	290 / 13	290 / 13	290 / 13
SUSPENSION					
Front	Pseudo Mac Pherson with lower triangle				
Rear	Torsion Beam				
STEERING					
Power assisted	Electric with variable assistance				
Turning circle between kerbs (m)	10.72m	10.72m	10.72m	10.72m	10.72m
WHEELS / TYRES					
Standard Wheel Size in inches	17 / 19	17/19	17/19	17 / 19	17 / 19
Spare wheel					
FUEL TANK CAPACITY					
Fuel tank capacity - Litres (Gallons)	55 (12.1)	55 (12.1)	55 (12.1)	55 (12.1)	N/A
WEIGHT					
Kerb Weight	1333	1333	1362	1428	1443
Gross Vehicle Weight	1889	1889	1918	1978	1994
Maximum Gross Train Weight	3389	3389	3418	3328	3344
Payload	2864	2864	2864	2864	2864
TOWING CAPACITY					
Max (Driver only) Towing weight = braked	1500	1500	1500	1350	1350
Max (Driver only) Towing weight = unbraked (17" / 19")	700	700	715	750	750
Maximum load weight on roof	72	72	72	72	72
SERVICING INTERVALS					
Service intervals	18,000 miles or 1 year whichever is the sooner				

*WLTP figures shown are for comparability purposes; only compare figures with vehicles tested to the same technical procedures. Actual real world driving results may vary depending on factors such as weather conditions, driving styles, vehicle load or any accessories fitted after registration. WLTP is a new test used for fuel consumption and CO₂ figures however until April 2020 the CO₂ figures are based on the outgoing (NEDC) test cycle which will be used to calculate vehicle tax on first registration. Please visit renault.co.uk/configure for WLTP figures for any selected options.

Renault Services

3 Years Warranty

Your vehicle is covered by a warranty package for up to 3 years from date of first registration (unlimited mileage during the first 24 months, followed by a further 1 year limited to a total mileage of 60,000). Your Renault Dealer is able to repair or replace without charge, parts that are found to have a material or assembly defect that is recognised by Renault. The paintwork warranty runs for 3 years and the anti-corrosion warranty for 12 years.

For Warranty Terms and Conditions please visit www.renault.co.uk/warranty

3 Years Roadside Assistance

Should you need it, we'll provide emergency roadside repairs or tow you to the nearest Renault Dealer. This service is available 24 hours a day and is provided for 36 months from the date of first registration. Assistance is provided within the UK & Northern Ireland only at roadside, home and includes national recovery and onward travel. Renault Assistance applies to mechanical or electrical defects which are covered by warranty.

For Renault Assistance Terms and Conditions please visit www.renault.co.uk/assistance

EasyLife Pack - £299*

Renault's EasyLife Pack is the ultimate package to provide care free servicing for the first 3 years or 30,000 miles (which ever is sooner). It really is the hassle free way to take care of our Renault and benefits from;

- Inflation Proof Servicing - You know exactly what you'll pay and there are no hidden costs
- Peace of Mind - No matter where life takes you, we'll be there in over 5000 workshops across Europe
- Renault Expertise & Quality - Our highly trained technicians know your Renault inside out

The EasyLife Pack contains Renault services in-line with the manufacturer's service schedule, plus comes with a complimentary vehicle health check to ensure your Renault is in the best condition possible.

EasyLife servicing and warranty enhancements also available. Refer to the Price Guide for more details.

Finance options**

There are a wide variety of ways in which the purchase of a new vehicle can be financed. Renault Finance offers all of them, so whether you're a fleet buyer or private buyer, Renault Finance is ideally placed to tell you which plan or combination of plans best suits your needs and circumstances.

Renault car insurance option¹

A car as well designed as your Renault deserves an insurance policy to match. Renault Insurance comes with a 5 Star Defaqto^o rating and has been specifically created to provide superb protection for you and your car. In addition to a very competitive premium, Renault Insurance also includes: Renault approved parts fitted in Renault Accident Repair Centres, protecting your 12 year anti-corrosion warranty; repairs guaranteed for 3 years; a courtesy car for the duration of any repairs - subject to availability when you use an approved repairer; payment by instalments - subject to status.

Renault car insurance:

0330 102 8833[†]

www.renaultcarinsurance.co.uk

Lines are open Monday - Thursday 8.30am - 7.30pm, Friday 9am - 6pm, Saturday 9am - 5pm.

Renault iCare

Is an innovative Service, Maintenance & Repair product that supplies Business customers with a fully supported, managed hassle free service and maintenance package. Renault iCare is a "Pay-As-You-Go" product that insures your vehicle is maintained by Renault technical experts when work is required.

iCare provides the following benefits:

- Full Service, Maintenance & Repair cover in the Renault Dealer Network
 - Tyres can be included within the contract at an additional fixed cost
 - Ancillary equipment can also be included (at an additional fixed monthly cost)
 - Excludes: Damage/Neglect/Abuse/Glass & Bulbs

- A fixed, pre agreed pence per mile rate
- No excess mileage charges at the end of the contract
- No pooled mileage administration
- Minimalise downtime

For more information and to obtain a quote based on your requirements, please speak to your local Renault Business dealer or visit www.renault.co.uk/icare

Customer Relations

Renault knows the value of communicating with its customers and we have established effective ways to keep in touch with you. If after speaking to your local Renault dealership you are not completely satisfied, please contact the Renault UK Customer Relations Department on 0344 3350000[†] (Mon-Fri 9.00am to 5.30pm, except Weds 10.00am to 5.30pm. Closed on Bank Holidays). You can also visit our website www.renault.co.uk or write to us at: Renault UK Ltd, The Rivers Office Park, Denham Way, Maple Cross, Rickmansworth, Hertfordshire, WD3 9YS.



*For EasyLife Pack terms and conditions visit www.renault.co.uk/easylife. EasyLife Pack is available for vehicles, excluding ZOE and LCV (Traffic Passenger and Master Combi are also excluded) ordered between 21st December 2018 to 1st April 2019. **Finance provided by Renault Finance, P.O. Box 149, Watford, WD17 1FJ. Guarantees and indemnities may be required. You must be at least 18 and a UK resident (excludes Isle of Man and Channel Islands) to apply. Subject to status, terms and conditions apply. [†]Calls to 0330 numbers are free if used as part of your inclusive mobile minutes and are charged at local rates from landlines. ^oDefaqto is an independent researcher of financial products. ¹Renault Insurance is provided by Original Insurance Services Ltd, registered in England and Wales No. 05686831 at Batchworth House, Church Street, Rickmansworth, Hertfordshire, WD3 1JE and is authorised and regulated by the Financial Conduct Authority. It is underwritten by Allianz Insurance plc, registered in England No. 84638 at 57 Ladymead, Guildford, Surrey, GU1 1DB. Allianz Insurance plc is authorised by the Prudential Regulation Authority and regulated by the Financial Conduct Authority and the Prudential Regulation Authority (Financial Services Register No. 121849). Renault UK Limited (company number 82932), registered at The Rivers Office Park, Denham Way, Maple Cross, Rickmansworth, Hertfordshire, WD3 9YS.

Extend the Renault Kadjar experience
at www.renault.co.uk

Although every effort has been made to ensure that the information contained within this brochure is as accurate and up to date as possible, Renault U.K. reserves the right to modify its models without notice, including their characteristics, specifications, equipment and accessories. Brochures inevitably become out of date or inaccurate in some respects, in that such characteristics, specifications, equipment, or accessories may be changed after the publication date given below and can differ from the descriptions given or the photos displayed. It is therefore necessary to check with your Renault Dealer before purchasing any product that the characteristics, specifications, equipment or accessories of the vehicle on order are as advertised.

Renault recommends 

 Prodigious

Photo credits: U. Heckmann, P. Giardino, Corbis, Getty Images, E. Haveric, Y. Brossard, A. Bernier, © Renault Marketing 3D-Commerce – Printed in EC – 7701 380 819 – 1 January 2019